

MANIFOLD CHAMBER L

A geothermal manifold chamber for ground probes and ground-coupled heat exchangers, fully prefabricated and tested at the factory.

Freely configurable thanks to selectable connection orientations, pipe diameters and an extensive range of accessories.

The probe connections are routed through the chamber wall to the outside and are prepared for electrofusion sockets, ensuring quick, safe and permanently leak-proof installation.

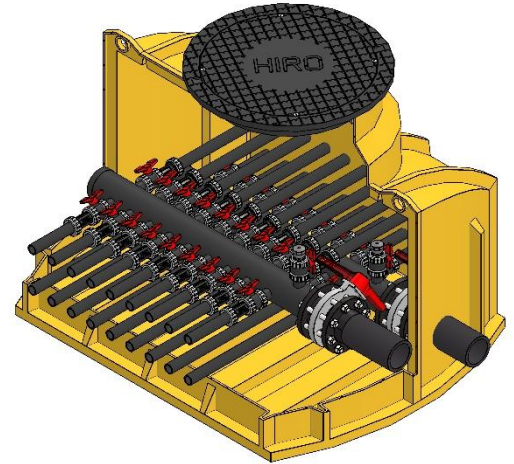

Height [mm]	1.210
Footprint [mm]	1.200 x 1.610

TECHNICAL DATA

- Shaft body made from 100% polyethylene without foaming additives, in a watertight design, manufactured seamlessly using rotational moulding
- Pressure-water-tight probe connections, factory-tested
- Manifold DA 90 -180, PE100 RC pipe SDR 11 PN16, suitable for water mixtures containing standard corrosion and antifreeze additives
- Includes 1" PVC ball valve for filling/venting
- Operating temperature: -20 to 40°C
- Operating pressure: up to 3 bar
- Test pressure: 12 bar
- Up to 22 brine circuits with individual shut-off (PVC ball valve DN 25 with EPDM seals)
- Probe diameter DA 32, 40 (SDR 7.4) or 50 (SDR 11)
- Probe spacing 100 mm (130 or 150 mm on request)
- Flow meter DN25 in selectable measuring range variants
 - 4-12, 10-27, 15-40, 20-60, 28-82 l/min
- Connection to brine pump available with or without shut-off valve
- Groundwater-resistant in standard version up to the middle of the shaft body, with optional reinforcement against water pressure up to the top edge of the shaft cover

NOTE

Installation, connection and commissioning must be carried out strictly in accordance with the manufacturer's current installation instructions!